

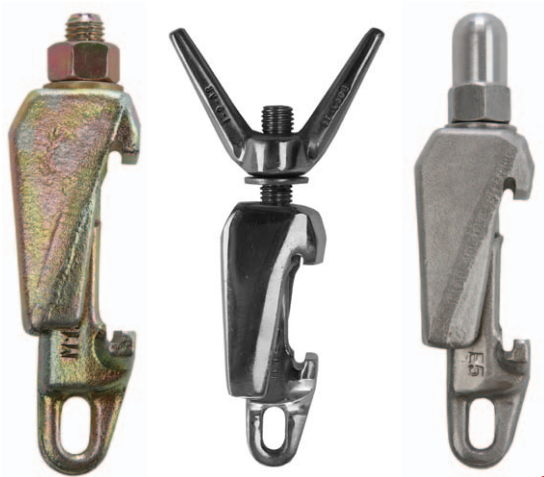

Cáncamos roscados "Interforgia" para cierre de bridas



- Reactores, equipos de presión, filtros presurizados, columnas evaporadoras, secaderos rotativos, como componentes especiales, etc.

Tipos de calidades (material forjado):

Acero: 25CrMo4 (WNR.1.7218), ASTM A193 Gr.B7.

Acero Inox.: AISI 316L (WNR.1.4404), ASTM A193 Gr.B8M.

Certificados

De calidad: EN10204 3.1 ó 97/23/EC-PED.

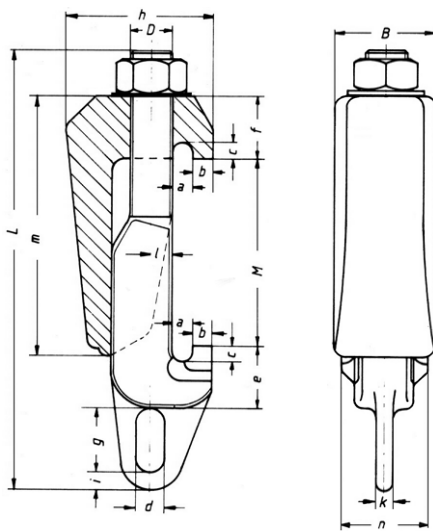

Tuercas standards



Tuerca pasante

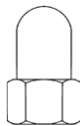

Tuerca ciega

Tuercas sobre demanda



Tuerca de ojo



Palomilla

Tipo	Apertura		Longi.Grueso			Dimensiones								Peso kg/pza	
	D	M	L	B	a	b	c	d	e	f	g	h	l		m
M 10-K	13 - 24		83												0,16
M 10-L	22 - 33		94	25	4	4	4	6	13	12	15	27	5	43	0,18
M 10-LS	70 - 83		122												0,22
M 12-L	40 - 56		133	34	4	5	4	8	18	20	16	38	6	70	0,50
M 16-K	40 - 60		165												1,13
M 16-L	55 - 85		192	40	6	7	5	12	25	25	25	58	100	32	1,21
M 16-L2	80 - 110		213												1,28
M 16-LS	95 - 125		234												1,40
M 20-K	50 - 75		195												1,95
M 20-L	65 - 90		212	48	10	9	8	14	30	30	30	73	10	115	2,00
M 20-L2	90 - 130		252												2,20
M 24-K	65 - 95		230												2,65
M 24-L	90 - 130		265												3,00
M 24-L2	120 - 160		295	52	10	11	8	14	34	34	30	78	12	130	3,20
M 24-LS	155 - 200		335												3,40
M 24-LP	180 - 260		404												4,40
M 24-LX	290 - 330		470												4,80
M 27-K	90 - 110		290												4,80
M 27-L	115 - 145		327												5,00
M 27-L2	150 - 195		375												5,15
M 27-L3	205 - 255		435	63	10	16	8	14	52	45	40	85	15	155	6,15
M 27-BV	250 - 300		480												7,20
M 27-LS	340 - 385		565												7,70
M 27-LX	440 - 480		680												9,50
M 33-K	100 - 150		380	75	12	20	10	24	65	60	48	104	18	205	9,20
M 33-L	150 - 200		430												10,10
M 33 Spec	180 - 220		440	70	12	20	10	24	63	56	48	102	18	200	10,20
M 33-L2	200 - 250		480												10,80
M 33-L3	250 - 300		530	75	12	20	10	24	65	60	48	104	18	205	11,40
M 33-LX	380 - 430		665												13,50
M 33-LY	510 - 560		810												16,50
M 56-L	200 - 245		523												30,15
M 56-L2	260 - 350		640	115	14	26	10	22	84	65	40	160	30	310	34,00
M-56-L3	380 - 420		705												41,30